

Fall...
ON THE ROAD

NOVEMBER 8, 2017 \ SPECIAL SUPPLEMENT TO THE

GASCONADE
COUNTY

Republican

FEATURE STORY:
The evolution of a
'67 Chevy truck



Magazine Shoot

While at a car show in Springfield in 1999 Randy Schweer was approached by 4x4 Power Magazine and asked to participate in a photo shoot for the magazine's cover. The shoot was done at a spring-fed stream outside of Springfield. One of the photos was published on the front cover in the June 2000 edition. See page 7B for a photo of the magazine.



PHOTO SUBMITTED

Bang Up Job? Don't worry!!

We'll set it straight without putting a big dent in your wallet.



Since 1981

- Auto Refinishing • Frame Straightening
- Car-o-liner Unibody Repair System
- Air Filtration Downdraft Spray/Bake Paint Booth
- Guaranteed Paint Colormatch
- ASE Certified Technicians • Written Warranty



302 N. 1st St., Owensville 573-437-2240

JIM KREUTZER, Owner
573-437-3636
573-308-5349 cell



We work on domestic & foreign vehicles, diesel & gas engines, and big trucks including road tractors



DRAKE AUTOMOTIVE

OPEN MONDAY-FRIDAY 8 TO 6; SATURDAY 8 TO 1; SUNDAY BY APPT.

2 MILES OUT OF DRAKE ON MORRE ROAD



Coverdell Auto Glass, LLC

Auto Glass and Window Tinting

AJ Brandstetter

502 S. Franklin
Cuba, MO 65453

573-885-4199

Fax 573-885-4293

Email: abrandtinter1@hotmail.com

The evolution of a '67 Chevy truck

BY ROXIE MURPHY
REPUBLICAN STAFF WRITER

rmurphy@wardpub.com

Some projects are always a work-in-progress—even when they haven't been touched in a while. For Randy Schweer of Owensville, that project is a 1967 Chevy, four-wheel drive, red pick-up truck.

"I have not done anything with this truck since I joined the fire department in 2008," Schweer said.

The red three-quarter ton Chevy sits beautifully idle in the corner of Schweer's garage—it's red 383 Stroker engine quiet. It is a completely different truck than what he originally purchased.

"I paid \$1,600 for it in 1986," Schweer said.

Two years later, it really became a project. Schweer and his former brother-in-law Danny Aytes thought to switch the 1967 two-wheel drive frame with a 1977 chassis.

"If it wasn't for Danny, it would never have been done," Schweer said. "I worked on

a Saturday and he had the body completely off a two-wheel drive truck, and put it on a four-wheel drive chassis."

That wasn't the only modification. He had a friend paint the truck white and started going to mud runs.

For seven years, Schweer ran his truck at events. Then in 1995-96, he decided he was ready for a change. He had his friend Dean Gabathuler of Hermann paint the truck red.

"He painted it red the first time," Schweer said.

Another friend, George Scott of Union, worked with Schweer at Chrysler and helped him with wiring and brakes.

"I moved my gas tank from out behind the seat to under the bed like a Blazer," he said. "I bought the tank out at Miller's Salvage and we mounted it to the frame."

He also replaced the bed, bedsides, fenders and front fender wells.

By the time he was finished, Schweer realized the truck came out so nice, he didn't want to mud it anymore—he wanted to show it.

"I knew if I was going to show it I would have to make things nicer and fix it," Schweer said. "I started showing, but spent a lot of money redoing repainting and replacing."

"I used to go all over the mid-west; Indianapolis, Iowa, Nebraska," Schweer said. "Pretty well-known, this truck is."

One event he attended in Indianapolis, Ind. had 5,000 trucks there that he says would have blown his out of the water.

"Because of the year and model of my truck, a lot of people like it; 67-72 are real popular," Schweer said. "I have over 20 awards I got from these Jamborees I went to."

Schweer's awards line his living room wall and a corner of his garage.

During a rough patch, when the 1967 truck was all he had, Schweer went to Oklahoma and picked up parts at a junk yard to replace what was rusting.

"Oklahoma doesn't have as much of a rust problem," he noted.

A friend in Hermann that owns Out of Town Auto Body repainted the truck red.

In 1999, *4X4 Power Magazine*, a special

off of the *Four Wheeler* magazine asked Schweer to participate in a photo shoot for the cover.

He was at a show in Springfield when he was asked to participate in the photo shoot.

"We drove 15 miles away from the show to a spring-fed stream that had a crossing," Schweer said. "We staged our trucks in a field and one at a time, went to the stream to take pictures."

His truck made front cover of the magazine in June 2000 featuring the "Older Truck Special!" Schweer's article *Ain't Behavin'* fit the truck's style.

He was later asked to do a second photo shoot at a rock quarry in Cedar Hill, Mo. *Four Wheeler* ran the story in May 2004 *Eight great heavyweights*.

In 2007, he changed out the 350 crate motor he had purchased new from GM for an upgrade to its current 383 Stroker.

"I still found mud after I had been to all these shows—I still had mud under the

See '67 Chevy, Page 6B

EXCLUSIVE HOLIDAY OFFERS STARTING AT
0% APR FOR 72 MONTHS
PLUS \$1,000 FORD CREDIT BONUS CASH

YEAR END SALES EVENT

2017 FUSION 2017 ESCAPE 2017 F-150

The inspection is necessary. The appointment isn't.

READY TO SERVE

Quick Lane
 TIRE & AUTO CENTER

THE WORKS

\$39.95
 or less*

Synthetic Blend Oil Change • Tire Rotation
 and Pressure Check • Brake Inspection
 Vehicle Checkup • Fluid Top-Off • Battery Test
 Filter Check • Belts and Hoses Check



Go Further

HERMANN FORD

614 Market Street
 Hermann, MO 65041
 573-486-3113

www.HermannFord.com



* Offers available on 2017 model year vehicles only. \$1,000 Ford Credit Bonus Cash requires Ford Credit financing. Not all buyers will qualify for Ford Credit financing. 0% APR financing for 72 months at \$13.89 per month per \$1,000 financed regardless of down payment. Not available on Focus RS, Fiesta, Mustang Shelby GT350/GT350R, Ford GT, Super Duty and F-150 Raptor. For all offers, take new retail delivery from dealer stock by 11/30/17. See dealer for qualifications and complete details.



RANDY SCHWEER'S '67 Chevy Truck has been black, white and red while he has owned it. While it was a mudder many times it was dirt brown.

PHOTOS SUBMITTED

We're Looking Out for You



Have you reviewed your auto insurance policy lately? Chances are, we can provide you with the same or better coverage for less money. Plus, you'll get personalized service from local agents who care about you and your safety.

As an independent insurance broker we can search several companies to find you the **LOWEST PRICE!**

Charlie Oswalt Agent/Owner

CL Insurance Group LLC

729 W. Springfield
Gerald, MO 63037

573.764.5215
charlieoswalt@ipnagent.com
www.clinsurancegroup.com

Wade Hicks - Owner
Hicks Auto Sales & Autobody



1200 Highway 28 **573-646-3820**
Bland, MO • www.HicksAutoSales.com



2012
GMC Acadia
AWD, 3.6L V6

2009
Jeep Wrangler Unlimited
4WD, 3.8L V6,
4 Door



Over 90 vehicles to choose from

ROY BELLOIR

573-437-7700



505 Henry Street • Owensville, MO 65066 • RBelloir@hotmail.com



RANDY SCHWEER poses with some of the trophies the truck won.

PHOTO BY ROXIE MURPHY

Rector Radiator LLC

573-859-6198

110 Belle Ave
Belle, MO
65013

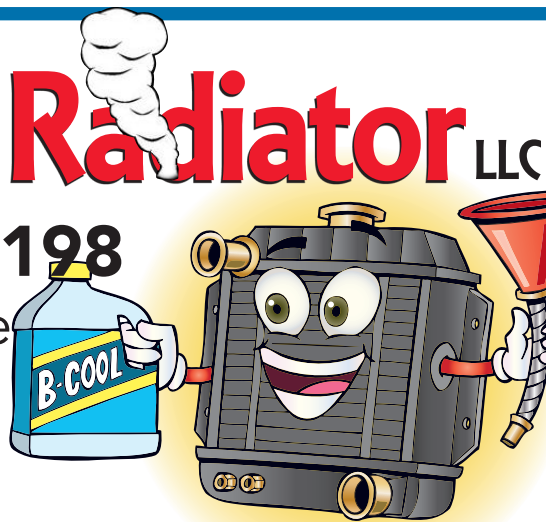

Full Service Mechanical Shop!



FREE Oil Change

One FREE 5 quart oil change using regular weight oil with appointment. Coupon expires 12/31/17. One coupon per household. Cannot be used with any other discount or promotion.





GROTE LIGHTING

Next-Gen lighting means next-level safety



\$7.99

Shell Zone Antifreeze



\$9.99

Anco Winter Extreme Contoured Wiper Blade



NOW IN STOCK...
Prestone Windshield Washer Fluid De-icer

We Have Hydraulic Fluid In Stock for:



John Deere, New Holland, Caterpillar, Case, & More!



Your one stop part shop
Over 15,000
Parts in Stock!

Guffey Auto ~ Auto Plus Auto Parts
711 Hwy 28 West • Belle, MO • 573-859-3651

CERTIFIED REPAIR LLC

AUTO AND DIESEL REPAIR

STEVE KAMPER

ASE CERTIFIED



Complete Auto Service:

Including: AC Repair • Tune-Ups • Batteries
• Brakes • State Inspections

15 West 5th Street, Gerald, MO

Shop: 573-764-5880

Cell: 573-259-8945



Fall Car Care

WED., NOV. 8, 2017 ■ PAGE 6B

GASCONADE COUNTY **Republican**

'67 Chevy • from page 3B

engine mounts," Schweer said.

From his time mud running, Schweer said he swears by cleaning parts such as California Customs, aluminum wheel spray and wax, and some McGuirs cleaning products.

"Best way to do it is let it dry a day or two and take a rubber hammer and just start tapping," he said. "Things will fall right off, but you don't want to get too carried away."

After he finished the last project, Schweer said he parked the truck.

"The last time I drove it was to one of the tail-gating football games when they wanted you to bring your old cars," Schweer said. "I took my granddaughter."

He noticed on that outing that the ol' truck may need a new bushing, which he plans on fixing. However, he says the passion he felt when he first started mud running and showing the truck are gone.

"I don't have it anymore," Schweer said. "I still enjoy going and doing stuff with it, but I am 63 years-old now and I am not working or have the money I used to."

But he remembers the addiction of getting started.

"When I got started, I just liked off-roading, driving, playing in the mud," Schweer said. "Boys will always have toys, they just sometimes get bigger."

Schweer plans on keeping the truck for his two grandkids, and hopes they will get the same kind of thrill he out of it.

"I never named it," he said. "My new passion is music."



FENDER BENDER?

We can help!

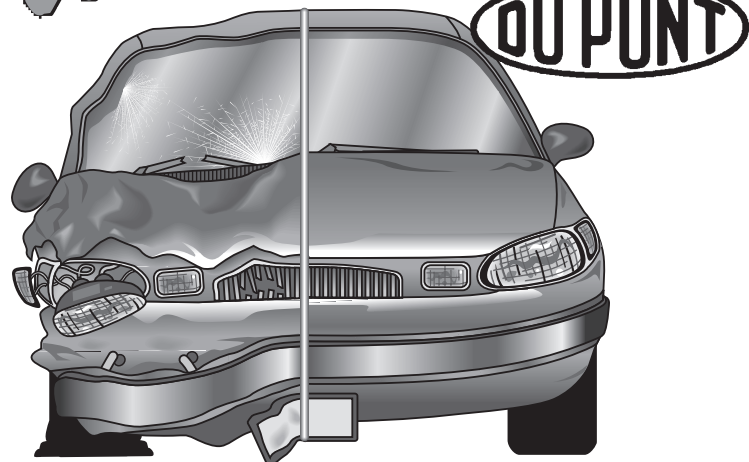

Whether your dear has a fender bender, or a deer bends your fender we can repair your vehicle to its pre-accident condition.

Our skilled technicians aim to please and your satisfaction is our long standing goal to success in business.

- ASE Certified Technicians • Body Repair - Structural and Non-Structural • Painting & Refinishing - DeVilbiss Concept II Down-draft Spray and Cure Booth • Factory Color Matching
- Windshield and Glass Replacement • Windshield Chip Repair
- Computerized Wheel Alignments • Towing Service
- Free Estimates • Insurance Work
- All Makes and Models

Family Owned and Operated Since 1934

WEHMEYER MOTORS, INC.

Rosebud,
MO



Phone
764-3331

Ask for Roy Wehmeyer - Body Shop Manager.

RAINERI Transmission & Auto Service

Complete Power Train Service

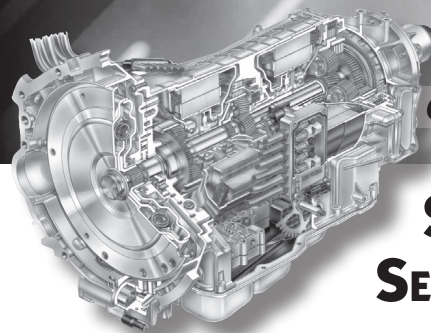

SPECIAL TRANSMISSION SERVICE AND REAR ENDS

ALSO STATE INSPECTIONS

...on Autos, Foreign
Cars and Large Trucks!

**MANUAL. AUTOMATIC. CARS. BIG TRUCKS.
SERVICE. QUALITY. RELIABILITY. ECONOMY.**

The next time you suspect transmission trouble, count on us. No matter what type of car you have, you'll find our level of service is way above standard.

WE ALSO CAN HANDLE FRONT END SUSPENSION, BRAKES
AND SOME ENGINE WORK

Call for an appointment today

573-437-8470

605 Raineri Circle • Owensville, MO 65066



Schweer's red '67 Chevy truck

Randy Schweer (above) with his, now red, '67 Chevy truck. The truck has been black, white and painted red twice before appearing in three national magazines (above right).

ABOVE LEFT PHOTO BY ROXIE MURPHY, OTHERS SUBMITTED





Midwest Auto Supply LLC
AUTO PARTS

Great people, great products, great prices!SM
Stock up Sale
1666 Hwy 28 W. • Owensville, MO 65066 • 573-437-PART (7278)

<p>PEAK® Long Life® Full Strength Antifreeze and Coolant Gallon ANT PRAOB3</p> <p>\$8.99</p> <p>\$53.94 CASE OF 6</p> 	<p>Purple Power® Cleaner/Degreaser 5 Gallon CCM 4325P</p> <p>\$19.99</p> 	<p>CARQUEST® Conventional Motor Oil</p> <p>\$1.79 Each</p> <p>When you buy 24 quarts (2 cases)* Reg. \$4.29 each Multiple viscosities available</p> <p>*Must buy 2 cases of 12 on the same ticket to receive discount</p> 	<p>CARQUEST® Synthetic Motor Oil</p> <p>\$2.99 Each</p> <p>When you buy 12 quarts (2 cases)* Reg. \$5.69 each Multiple viscosities available</p> <p>*Must buy 2 cases of 6 on the same ticket to receive discount</p> 	<p>CARQUEST® Heavy Duty Conventional Motor Oil</p> <p>\$9.49 Each</p> <p>When you buy 6 gallons (2 cases)* Reg. \$12.99 each CQO CQ645-1G</p> <p>*Must buy 2 cases of 3 on the same ticket to receive discount</p> 	
<p>ANY Zep® Hand Cleaner</p> <p>\$15.99 Each</p> <p>When you buy 2 gallons*</p> <p>Cherry, ZAM 1041522 Orange, ZAM ZUORA128 Easy Scrub, ZAM ZUEHC128</p> <p>*Must buy 2 gallons on the same ticket to receive discount</p> 	<p>CARQUEST® Full Strength Antifreeze</p> <p>\$7.49 Each</p> <p>When you buy 12 gallons (2 cases)* Reg. \$13.99 each ANT 301</p> <p>*Must buy 2 cases of 6 on the same ticket to receive discount</p> 	<p>CARQUEST® Dex III/ Mercon & Type F Transmission Fluid</p> <p>\$1.99 Each</p> <p>When you buy 12 quarts (1 cases)* Reg. \$5.39 each Also available in Dex VI, Mercon V and +4, \$3.29 each</p> <p>*Must buy 1 case of 12 on the same ticket to receive discount</p> 	<p>Wearever® Brake Parts Cleaner</p> <p>\$1.89 Each</p> <p>When you buy 24 cans (2 cases)* Reg. \$4.29 each WES S7340, WT341, W5090</p> <p>Also available in Non-Flammable for \$2.29 each with a 2 case minimum. WES W5089</p> <p>*Must buy 2 cases of 12 on the same ticket to receive discount</p> 	<p>Scott® Shop Towels</p> <p>\$1.89 Each</p> <p>When you buy 60 rolls (2 cases)* Reg. \$2.99 each SCO 75130</p> <p>*Must buy 2 cases of 30 on the same ticket to receive discount</p> 	<p>BlueDEF® Diesel Exhaust Fluid</p> <p>\$8.99 Each</p> <p>When you buy 8 boxes* 2.5 GL Reg. \$14.99 each OWI DEF002</p> <p>*Must buy 8 boxes on the same ticket to receive discount</p> 

Peak Antifreeze and Purple power prices good thru Nov. 11, all else thru Nov. 18, 2017

Shop 24/7 at CARQUEST.com. Buy online, pickup in store.

Locally Owned

Prevent breakdowns with battery care

Many drivers have experienced the misfortune of getting into their vehicles only to realize their engines won't turn over. Although there may be plenty of reasons why a car will not start, quite frequently a dead battery is to blame.

Car batteries can last for five years or more when properly cared for, but many batteries wear down and become inefficient within three years of daily use. According to the UK-based company Warranty Wise, car batteries deteriorate with every charge from a vehicle's engine. Naturally, drivers who are stranded by dead batteries wish they had done more to prevent their battery dying while they're on the road. Certain factors might offer clues as to how much life vehicle batteries have left.

- **Longer start time:** A dying battery may cause the engine to crank, but it can be slow to start or not seem to exude a lot of power.

- **Cranks but doesn't start:** You may turn the key to hear the engine trying to turn over, but it won't. Even if the vehicle eventually starts, have the battery checked and, if necessary, replaced by a mechanic.

- **A jump start has been necessary:** Batteries that have required a jump or multiple jumps are on their last legs and



should be replaced immediately.

- **Dim lights or check engine indicator:** Batteries powers the electric components in a vehicle, so dim lights could be indicative of a loss of power. Having the "check engine" light come on also can be a clue.

- **Extreme temperatures:** According to Firestone, hot or cold temperatures can shorten a battery's life. If you live in an extreme climate, your battery may not last as long as the manufacturer suggests it should.

- **Short driving trips:** People who take many short trips (less than 20 minutes each) may find their batteries do not have enough time to fully recharge, shortening their life expectancy.

- **Pungent aroma:** Leaking and corrosion around the battery terminals can cause battery issues. If there is a rotten egg smell under the hood, it may be a leaking battery on its way to dying.

Drivers can have their vehicle batteries tested by mechanics. Batteries can be replaced at home or at a garage. Servicing the vehicle frequently can prevent performance inefficiencies and help determine if any components are straining the battery and causing premature loss of battery life.

Curtman Insurance Agency
573-437-8258
curtmanagency@gmail.com
111 S. 1st Street, Owensville, MO 65066

Savings

It's a good thing when you're shopping for car insurance.

Independent insurance agents don't work for just one company and that means better choices for you. They can check out your coverage and compare rates with multiple insurance companies to make sure you are getting a great rate.

With great rates, coverage and claims service, it's no wonder that independent agents sell more car insurance from Progressive than from any other company.

Find out how you can start saving with Progressive today. Stop in or call Curtman Insurance Agency, your local independent agent, for expert advice and a free quote.

Call today!

Curtman Insurance Agency
573-437-8258

573-437-7331

604 S. Walnut • Owensville, MO 65066
Hours: Monday - Friday: 8 to 5 p.m.

WE NOW REPAIR GM INSTRUMENT CLUSTERS WITH INOPERABLE GAUGES AND DASH LIGHTS SEE US FOR DETAILS

• State Inspections	• AC Service
• Tune-Ups	• Oil Changes
• Brakes	• Computer
• All Engine Work	• Diagnostics



DRIVERS WHO want to save money can explore their auto insurance options before renewing their policies.

Successfully switch auto insurance providers

Once drivers purchase an auto insurance policy, many simply let the policy renew each year. But with a little digging, drivers may be able to reduce their insurance costs considerably.

According to the Insurance Information Institute in New York, consumers should ask themselves if they're happy with the cost, service and coverage of their existing policies whenever it's time to renew. If they are, they should stick with their existing policies. However, if customers feel things can be better, then it's a perfect time to see what's available. Many driver advocates advise shopping for a new policy every two or three years.

When it comes time to switch car insurance companies, follow these steps and remember to avoid gaps in the coverage.

- Compare apples to apples. When shopping for new policies, consumers should compare the same features offered by various providers, including coverage types, deductibles and any limits. Keep a copy of your existing policy's declarations page so that all quotes can be accurately compared to the existing policy.

- Research any cancellation fees. Before switching over, find out if there are any cancellation fees associated with an existing policy.

- Eliminate coverage gaps. Eliminate gaps in coverage by ensuring a new policy begins the moment the existing one ends. This prevents potential financial ruin should a driver get into an accident without any insurance during a gap period.

- Take note of any lifestyle changes. Be sure to list anything that can affect the cost of coverage, such as anti-theft devices on the vehicle, window etching or updated driving habits.

- Explore union or group affiliations. Drivers who are members of particular clubs, professional organizations or something similar may be eligible for special policies with certain providers. Make a list of any affiliations and contact the organizers to see if they have relationships with auto insurance providers. Law enforcement personnel or veterans may be eligible for certain discounts as well. Some insurance carriers only cover police officers or former military. It pays to look into these discounts.

- Consider small companies. Just because they don't advertise as much as some of the more well-known providers does not mean small insurance companies are not capable of providing sufficient, affordable coverage. There are plenty of reputable small companies that offer excellent rates to drivers willing to exercise their due diligence.

- Check with the existing provider, too. Drivers can discuss their current rates and coverage with their existing insurance company, who may offer suggestions on reducing coverage or even offer lower prices in an effort to hang on to customers. Consider these possibilities before switching.

Shopping around for a new automotive insurance policy may help customers cut rates and increase coverage.

ALL-NEW: The Ultimate Truck Bed Solution by UnderCover

A hard folding truck bed cover that comes standard with overwhelming new features, and is topped off with an alluring matte finish. The Ultra Flex is in a category of its own.

The Ultra Flex has been carefully crafted to be the ultimate all-purpose truck bed cover. Unprecedented features that come standard with each Ultra Flex include a **Saddlebag storage box** for convenient

out of the way bed organization, a dual rail **LED bed lighting system** for luminous bed lighting day and night, and an **easy-close tailgate seal**. Multiple riding positions allow the end user to ride with full access to their bed, and full weather protection is available for the bed if the cover is in the fully closed position. Ultra Flex is a no drill application and can be installed and removed easily with our newly designed "L-Rails." What's more, the Ultra Flex is backed by a **5 year warranty**, making it the most desirable folding cover on the market.



WeatherTech FloorLiner™ DigitalFit®

1st, 2nd, 3rd Row & Cargo Liners custom-fit for your vehicle to provide absolute interior protection!

Available in: 

Made in the USA



REFLEX
Sprayed-On
TRUCK LINERS

Enhances & Protects New - Used Trucks
OEM Paint Code Color Match Available
Preferred Over Drop-In Plastic Liners



TRUXEDO
Lo Pro QT

The Best Selling Tonneau Cover
In North America!

LIFETIME WARRANTY
Covers everything - even the fabric

COUPON

\$25 OFF

- Sprayed On Truck Liners
- Truxedo Lo Pro Tonneau Cover or
- Undercover Flex folding bed cover

Good thru Nov. 30, 2017 • Limit 1 coupon. Cannot be combined with any other sale or discount.

Accessories UNLIMITED LLC.

Complete Line Of Quality Accessories

www.EAccessoriesUnlimited.com

- Running Boards
- Tool Boxes
- Bug Shields
- Nerf Bars
- Bed Liners
- Bed Covers
- Professional Installation
- Performance Products
- Mud Flaps • Floor Mats
- Sprayed On Truck Liners
- Brake Controllers • Hitches
- Lift Kits & Much More...



5475 Hwy 100 East Washington, Mo.

(636) 390-9300



DEEZEE LUND

REFLEX
Sprayed-On
TRUCK LINERS

Safety first when traveling with pets

Pets' love is unconditional, so it's no wonder that pet parents want to keep their beloved animals by their side as much as possible. Pet owners whose pets spend ample time in the car should brush up on some safety precautions to ensure the roadways are safe for all travelers, including those covered in fur.

Driving while distracted is a significant safety concern. The AAA Foundation for Traffic Safety notes that simply taking one's eyes off the road for two seconds doubles the chances of being involved in a crash. Recent data from Kurgo, a leading supplier of quality dog travel supplies and accessories for active dogs, found that 60 percent of respondents had driven with pets in the last month, and more than half admitted to being distracted by their pets. Although the National Highway Traffic Safety Administration does not track how many accidents are attributed to pets, it's easy to see how pets can be a distraction on the road.

Drivers should never allow their pets to sit on their laps or ride in vehicles unless they are restrained. Doing so puts all passengers, pets and humans alike, in danger. AAA says a 10-pound dog that's not restrained can generate 500 pounds of force in a 50 mile per hour crash.

Pet owners can heed these safety guidelines to make trips with their pets less dangerous.

- Recognize that airbags can cause injury. Airbags are designed to protect people, not pets. It's always recommended that pets ride in the back seat or the storage area of an SUV in vehicles equipped with airbags.

- Watch those windows. Although riding with their heads out of the car window is a quintessential image of dogs in car, such situations put dogs in danger. Fast-blowing debris or litter can injure the dog, and heavy airflow can damage the animal's respiratory system, warn veterinarians. Dogs also may attempt to jump out.

- Invest in a restraint system. Vehicle restraint systems keep pets safe. Small dogs may benefit from being inside crates that are secured to the vehicle. Harnessing a pooch is another option, and many harnesses connect directly to seat belts. Dog gates and guards can be installed between the back seat and the storage bay area, which is great when traveling with multiple dogs.

- Avoid truck beds. The American Humane Society says pets should never be transported in the bed of pickup trucks. Dogs should only ride in pickup trucks with extended cabs that allow their owners to secure them in the backseat.

Keeping passengers, including both people and pets, safe in vehicles is the responsibility of drivers.



Make It *Yours*

Let us put you behind the wheel with a great low rate!



LEGENDS

BANK

New & Used Vehicles | Refinancing | Flexible Terms

MEMBER FDIC

Find us on:



www.legendsbk.com ■ 602 East Hwy. 28 ■ Owensville, MO ■ 573-437-LOAN



■ Linn ■ Belle ■ Bland ■ East Linn ■ Jefferson City ■ Loose Creek ■ Owensville ■ Rolla ■ Taos ■ Union ■ Westphalia

Improve the value of your trade-in

Trade-ins can reduce the cost of buying new vehicles and save drivers the hassle of selling their vehicles on their own.

Motorists who think trading in is the best way to unload their current cars can take various steps to improve the trade-in value prior to visiting the dealership.

- Know the trade-in market. Some trade-ins may be more valuable than others, even if the cars are relatively similar with regard to mileage. For example, preowned vehicle buyers typically prefer late model vehicles as opposed to cars that are older. This is even more apparent now that many car buyers want smartphone-friendly vehicles that afford them access to the apps and GPS systems on their phones. Drivers who want to get maximum value for their trade-ins may benefit by trading in a year or so earlier than they initially planned, as this will make their cars or trucks more attractive to prospective buyers.

- Address any issues. Dealerships will offer to tend to any repairs trade-ins may need, but that will come at a cost, which will be reflected in the trade-in value of the car. Vehicle owners should address any issues before taking their vehicles to the dealership.

Fix any doors that stick or minor scratches on the vehicle's exterior, remembering to have the car detailed, washed and waxed. Investigate if any major problems, such as engine troubles, are worth fixing on your own, or if you're better off receiving less for your trade-in.

- Keep maintenance records. Maintenance records illustrating that the vehicle was taken care of can help owners get more for their trade-ins.

- Shop around. Drivers who are not satisfied with the trade-in value assigned by a specific dealership can shop around until they find better offers. Some dealerships may not offer much for a vehicle because they already have a similar car or truck sitting on their lot, while others may jump at the chance to make their preowned inventory more diverse. Exercise patience when shopping around to reduce any frustration that might develop during the negotiation process.

Various factors impact the trade-in value of cars and trucks. When purchasing new cars, vehicle owners can employ various strategies to get the most money for their current automobiles.

Full Auto Glass Replacement

- **Paintless Dent Removal**
Hail Damage ~ Door Dings
- **Full Auto Glass Replacement and Chip Repairs**
- **Automotive Accessories**
Running Boards, Leveling Kits, Lift Kits, Performance Upgrades
- **Headliner Replacement**
- **Oil Changes**
- **Brake Service**
- **Towing/Rollback Service**
- **Check Engine Light Diagnosis**

WHITE AUTO GLASS WHITE MOTOR CO.

In business for over 60 years

212 Hwy. 28E • Belle, MO
573.859.6324



Faith Auto LLC

- ❖ COMPLETE AUTOMOTIVE REPAIR
- ❖ AUTO BODY REPAIR/PAINTING
- ❖ PRE-OWNED CARS FOR SALE

Owned by Charles DeBoeuf
573-437-7001
201 E. Harrison, Owensville, MO

FILL YOUR TANK

With the Money You Save on Auto Insurance!

Call Today for a FREE Policy Review & Rate Quote. 573-437-2100

The Insurance Center

Agents **Brian Rooney** and **Steve Havelka**
112 N. 7TH • OWENSVILLE, MO
PH 573.437.2100
EMAIL: brooney01@hotmail.com

Mullin's Auto Parts

NOW SELLING

ALTERNATORS ~ AC COMPRESSORS POWER STEERING PUMPS ~ STARTERS COIL PACKS BLOWER MOTORS ~ CV AXLES ~ MUCH MORE

For Almost **Half the Price** of remanufactured parts at other parts stores. Check out our inventory on engines and have us install it for a fraction of the cost of other shops. All of our parts have a 90 day warranty however we offer extended warranties at an additional low rate!

BRING THIS AD IN TO RECEIVE
10% off your next purchase of \$100 or more!

(Coupon good for in stock items only. Limit one per person Expires 12/31/2017)

Call us today at 800-392-5302 or 573-484-3344

3191 Highway 50 • Beaufort, MO

Choosing a vehicle based on wheel drive

Several factors are considered before drivers purchase new vehicles. Wheel drive may not be the first such factor to come to mind, but it can be an important consideration when car shopping.

Despite the considerable rise in popularity of sport utility vehicles, automotive expert Edmunds says most passenger cars sold in the United States today use a two-wheel-drive system. With options such as 4WD, AWD, FWD and RWD, consumers should understand the differences of each type of drive in order to make the most informed decision.

Rear-wheel drive

With rear-wheel drive, the power goes to the back wheels to drive the vehicle. This used to be the system of choice because RWD systems were relatively easy to manufacture, offers Kelly Blue Book. RWD is the choice for many trucks because added load can offer additional traction in the back. Furthermore, rear-wheel drive is coveted for sporty vehicles and luxury cars. That's because, as vehicles accelerate the weight is transferred to the rear wheel, enhancing traction and further acceleration. This drive also

distributes weight more evenly, so cornering and handling is better.

Front-wheel drive

The National Motorists Association states that front-wheel drive, which has become ubiquitous in cars produced today, is cheaper to design and build than RWD. Fewer parts mean the drivetrain is easier to install. It is also less heavy than others, helping vehicles to be lighter and consume less fuel. In rain and snow, FWD has excellent traction, so it's an asset under poor weather conditions. Front-wheel drive vehicles are not prized for their handling because the front wheels have to put power to the ground and steer the car. Furthermore, unlike RWD, which is more rugged and durable, FWD is more fragile.

4-wheel-drive & All-wheel-drive

4WD is designed for rugged, off-road applications and AWD is for pavement driving. Pure 4WD is good for low-traction situations off of pavement, where additional grip is needed. In some 4WD vehicles, this drive needs to be engaged through a transfer switch. In such automobiles, the vehicle operates in FWD or RWD until that switch is engaged.



APART FROM passenger seating, horsepower and color, wheel drive should be a consideration when car shopping.

All-wheel-drive provides the best of FWD, RWD and pure 4WD systems. The main advantage is excellent traction on both dry pavement and in poor weather. Some AWD vehicles may be able to go off-roading as well. Potential disadvantages to AWD include cost, vehicle weight and, because there

are more components in AWD, more parts can fail and require servicing. AWD typically comes in part- and full-time versions.

Choosing a wheel drive requires an understanding of how one plans to use the vehicle and which attributes are most important.

Collision Repair and More

WINDSHIELD REPLACEMENT & CHIP REPAIR



Get your windshield repaired at no charge to you. Windshield Chip Repair is covered 100% by most insurances, with no deductible.

Windshields Replaced If Needed

AUTO DETAILING

Everything from Hand Wash Jobs to Complete Auto Detailing

RENTAL CARS - DAILY OR WEEKLY

Serving the area for over 35 Years!

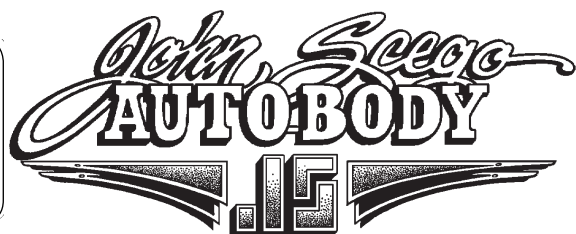

302 N. 1st St., Owensville **573-437-2240**

Joseph

Skornia's Auto Repair

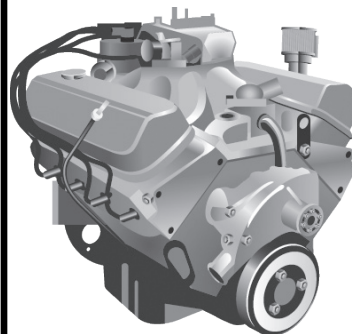

- Tune-Ups • Brakes • Tires
- Batteries • Lube Jobs • Engine Work
- Suspension Work • Drive Line
- Computer Diagnostics • & more

Joseph and Teresa Skornia
DBA-Skornia's Auto Repair
4E 6th Street
Gerald, MO 63037
(6th Street And South Main)

(573)764-4487



INSURANCE COMPANIES, HOME OFFICES: BLOOMINGTON, ILLINOIS

DOUGLAS N. KNEHANS

Agent

105 E. Peters
P.O. Box 95
Owensville, MO 65066
Office: 573-437-2101
Fax: 573-437-7765
Home: 573-437-3842

47
YEARS
REPRESENTING
STATE FARM
INSURANCE

Safety measures for winter drivers

Winter weather causes many people to retreat indoors until the spring thaw. However, for those who embrace the cooler temperatures or find that life must go on despite snow and ice, taking inventory of their vehicles is a must before the first snowflakes start to fall.

Tire care is an especially important area of vehicle maintenance. The tire experts at Michelin say that regular tires may be ineffective for winter driving. Summer tires are made from materials that are optimized for warm conditions. When the mercury drops, these same materials can harden, reducing their ability to grip the road. That lack of traction can be compounded by the presence of snow or ice. Even all-season tires, which are designed to be driven year-round, can be insufficient in severe weather conditions. Winter tires can help drivers safely navigate winter roadways.

Bridgestone Tires says that having the right snow tires matters when driving in winter weather conditions. It's important to look for tires that can disperse water sufficiently and also grip the road. Snow tires are designed to remain softer and more flexible to conform to the road better in cold conditions. Some winter tires are even studded to provide better traction.

Unfortunately, even the best winter tires cannot provide perfect traction on slippery roadways. That is why it is essential — in conjunction with the use of winter tires or snow chains — to modify driving techniques to navigate safely.



- Drive slowly. Slow down on winter roads. Allow a greater distance for stopping than for dry conditions. Slippery conditions can make it more challenging to stop, and excessive speeds can make the situation worse.

- Shift into low gear. On hills, rely on low gears to maximize traction to travel up and down hills. This can minimize skids or sliding.

- Get the vehicle a tuneup. In addition to tires, be sure the braking system, battery and other major components of the vehicle are in good working order.

- Replace windshield wipers. Reduced visibility can

compromise the safety of drivers and their passengers. Replace windshield wiper blades before winter arrives. Consider purchasing winter-rated windshield blades.

- Know how to recover from a skid. When skids occur on black ice or slush, drivers should take their feet off of the pedals and steer gently in the direction they want to go. As the vehicle regains traction, only then should the brakes or accelerator be applied.

Winter weather requires making some vehicle modifications, and drivers may want to alter the way they drive to be more safe on the road.

Central Tire

Sales and Service, LLC

106B South L & D Drive • Owensville, MO 65066

George
(573) 578-5582

573-437-2999

Chuck
(573) 578-5082



We are proud to carry
Firestone
Passenger & Light Duty Truck Tires



On Site Repairs

INSTANT REBATE COUPON

Hunter Front Wheel Alignment

\$49

HUNTER
Engineering Company

Instant Coupon
See Store for Details!

Coupon good for most vehicles. Some exclusions apply. Must present coupon at time of service. One coupon per service. Cannot use in combination with any other special or promotion. Offer expires 11/30/17.



AutoCare
Express

404 S. Hwy. 19 • Owensville • 573.437.6000



Help senior drivers maintain their independence

As men and women age, various factors may affect their ability to drive. In addition to issues with memory, seniors may have failing eyesight and physical limitations, and their reaction time may slow down. In such instances, seniors' ability to safely operate a motor vehicle may be questioned.

Age alone is not a reliable measure of driving ability, but many of the issues that affect one's ability to safely drive a vehicle tend to appear as men and women near their golden years.

Losing the ability to safely operate an automobile can greatly reduce a person's independence. That is why periodic driver evaluations may be met with some reluctance. Aging men and women who don't want to avoid potential conflicts with concerned family members can take their own steps to ensure they maintain their ability to safely operate a motor vehicle.

Schedule a driving safety evaluation

When drivers' abilities to operate a motor vehicle become suspect, a thorough evaluation should be scheduled. The evaluation should not be handled by a family physician or family member, but by an unbiased third

party like a Certified Driving Rehabilitation Specialist. This is a therapist who has special certification to assist people with disabilities, including older adults, with driving. They can help individuals with adaptive equipment or techniques if driving issues stem from something that can be addressed.

Figure out if the car "fits" the individual

A program called CarFit can help drivers assess if their car is suited to their abilities. A team of trained technicians and/or health professionals work with participants to ensure their vehicles are equipped for maximum safety and comfort. A properly adjusted vehicle is as important as one's cognitive and physical abilities. Adjustments can include mirror placement, good foot positioning and sitting at the proper distance from the steering wheel. People can learn about an upcoming event at www.car-fit.org.

Take a driver improvement course

Driver improvement courses are provided by various organizations, including some insurance companies. AARP also has a Driver Safety Course to lower the risk of traffic violations, collisions and injuries.



Completion of these courses can help drivers enhance their abilities behind the wheel and may result in lower premiums for mature drivers.

Keep the mind and body fit

Regular exercise and a healthy diet can be assets for mature drivers. Mental fitness techniques and brain exercises can

improve reaction time, while aerobic and strength-training workouts can keep the body in shape.

Driving is one of the key avenues to personal independence. Strengthening seniors' driving abilities is a goal of many organizations.

L. Stewart Automotive, LLC
Larry & Janet Stewart ~ Owners

Take advantage of our expertise – see us for computer diagnosis, regular maintenance on all foreign and domestic automobiles.

- Full Service Garage
- Front End Alignment • Tune Ups
- Fuel Injectors Cleaned • AC Work
- Oil Change • State Inspections

600 North 1st Street • Owensville, MO 65066 • 573-437-2437

REDUCE ■ REUSE ■ RECYCLE ■ REDUCE ■ REUSE ■ RECYCLE

WE BUY: All Types of Aluminum ~ Copper ~ Brass
Car Radiators & Batteries
Catalytic Converters Much More!

RECYCLING ZONE

Why trade it in? Sell it for more \$\$\$

Get Cash for it!

573-437-5050

1640-B, Highway 28 ■ Owensville, Missouri 65066

REDUCE ■ REUSE ■ RECYCLE ■ REDUCE ■ REUSE ■ RECYCLE

PROTECTION WHILE YOU'RE ON THE ROAD.

Your dreams deserve more than an insurance card tucked in your glove box. That's why I go beyond a piece of paper to give you smart, customized coverage and real peace of mind to pursue what matters most. Contact me today for a competitive quote. **Let's talk today.**



Theresa Ditto Agency
American Star Excellence
In Customer Experience
109 S 1st St, Owensville, MO 65066
(573) 437-3726



Insure carefully, dream fearlessly.

American Family Mutual Insurance Company, American Family Insurance Company, American Standard Insurance Company of Ohio, American Standard Insurance Company of Wisconsin, 6000 American Parkway, Madison, WI 53783
The General®, 2636 Elm Hill Pike, Nashville, TN 37214 ©2016 011765 - 4/16



Why clean air filters are important

Vehicle owners likely know to check fluid levels and get their cars' oil changed, but air filters may not be at the top of their maintenance checklists. Despite being a relatively inexpensive part, air filters often go overlooked.

Air filters have an important job in a vehicle, prolonging the life span of engines and helping cars run more smoothly and efficiently.

Purpose of vehicle air filters

Vehicle combustion engines operate with a mixture of fuel and air. Without oxygen, gasoline or diesel fuels cannot burn properly and power the engine. The air filter's job is to prevent dirt, dust and other debris from being sucked into an engine. Otherwise, grime can build up and impede engine performance or cause erosion of parts under the hood.

It is much more cost-effective to routinely change air filters than replace expensive engine parts. Rather than ignoring air filters until the last minute, drivers can take steps to keep filters clean and functioning at peak performance.

- Improve fuel efficiency. Clogged air filters reduce air flow to engines, resulting in

an improper ratio of air to fuel. As a result, spark plugs can be negatively affected and the engine may idle roughly or misfire. These scenarios can greatly affect fuel efficiency as well as cause engine deposits from rich fuel. To save money and trips to the fuel pump, replace filters regularly. According to GearHeads, for older cars, studies have indicated that by replacing a dirty air filter, one can improve gas mileage by as much as 14 percent.

- Reduce stress on the engine. Because of the air-to-fuel mix in engines, even a mixture that is slightly off balance can affect what is going on under the hood. That means the engine must work harder to get enough clean air into the chamber to complete the combustion cycle, says the Automotive Training Center.

- Enjoy more power. A filter that is saturated with dirt will restrict air flow. In such instances, drivers may notice a lack of power during acceleration. Replacing the filter can easily restore that pep.

- Reduce vehicle emissions. Environmental concerns are a priority for many people. By keeping the engine working properly,



REPLACING AIR filters is an inexpensive way to keep vehicles performing at peak capacity.

with the advantage of clean, unobstructed air entering the chamber, a vehicle may produce lower emissions.

Replacing air filters is an easy fix that

many drivers can do themselves, or ask their mechanics to do during oil changes or other repair shop visits.

BLACK FRIDAY
ALL MONTH LONG

CERTIFIED SERVICE

TRENARY SERVICE SPECIALS

**OIL CHANGE,
4-TIRE ROTATION**

\$15⁰⁰
MAIL-IN
REBATE

On the purchase of an ACDelco DEXOX1 Oil Change with a 4-Tire Rotation and Multi-Point Vehicle Inspection, or a Mobil 1 Oil Change Only.

See dealer for details and rebate form, which must be postmarked by 12/31/17

Expires 11/30/2017

\$100
TIRE REBATE

\$100 Mail-in Rebate (Debit Card) on a set of 4 tires from Bridgestone, Continental, Goodyear, Hankook and Pirelli.

See dealer for details and rebate form, which must be postmarked by 12/31/17

Expires 11/30/2017
Coupon Code: 301

**MOST AC/DELCO
PROFESSIONAL BRAKE
PADS INSTALLED**

\$109⁹⁵
per axle*

Includes rotor inspection, 12-month/unlimited miles limited warranty. Turning or replacing rotors, all other services, and tax extra. Excludes Corvette and other select vehicles.

Expires 12/31/2017
Coupon Code: 203

**FRONT-END
ALIGNMENT**

\$49⁹⁵

Check steering, suspension and shocks. Set toe-in, chamber and caster (where applicable). Check tie-rods and ball and more. See dealer for details. Tax extra.

Expires 11/30/2017
Coupon Code: 41

FIND NEW ROADS™

Jim TRENARY
OF UNION, MO

Phone: **636-583-8000**
Hwy. 47 at Hwy. V
Union, MO 63084
www.JimTrenayrUnion.com



CHEVROLET



GMC
WE ARE PROFESSIONAL GRADE



FALL SALE

ALL TIRE PRICES INCLUDE MOUNTING AND COMPUTER BALANCING

GOODYEAR



GOODYEAR WRANGLER RADIAL

\$95⁰⁰ 235/75R15

All-Season tires. Developed for use on new cars and light trucks, these tires provide a versatile blend of ride quality, noise comfort, treadwear, handling and year-round traction, even in light snow.

Full Service Kendall Oil Change

 **Kendall GT-1 Engine Oil** **\$28.00**

 **Kendall Super D_{XA} Diesel Engine Oil** **\$65.00**

Limited time offer. Some restrictions apply; see store for details.

WE DO BRAKES & EXHAUST WORK

Stop in today for an evaluation of your vehicle's brakes and exhaust system!



NOW DOING

Hunter Hawkeye Elite Alignments

Come by today for a Quick Check!



61 years of doing it right...has made Jost Tire the Leader!
See Jost Tire, your independent Tire Dealer, for any of the following brands...



— including ATV & Lawn/Garden!



Matthew Jost and Steve Baehr
JOST TIRE CO., INC.

116 E. PETERS AVE., • OWENSVILLE, MO 65066
 573.437.TIRE (8473) • www.JostTire.com

